

DEBIX LoRa Board User Guide

Version: V1.0 (2023-07)

Compiled by: Polyhex Technology Company Limited (<http://www.polyhex.net/>)

DEBIX LoRa Board is compatible with DEBIX Model A/B and DEBIX Infinity, and provides a Mini PCIe interface for LoRa Module. LoRa enables long-range transmissions with low power consumption. In addition to a LoRa Antenna Connector, it also has a Wifi Antenna Connector and Bluetooth Pairing Button.

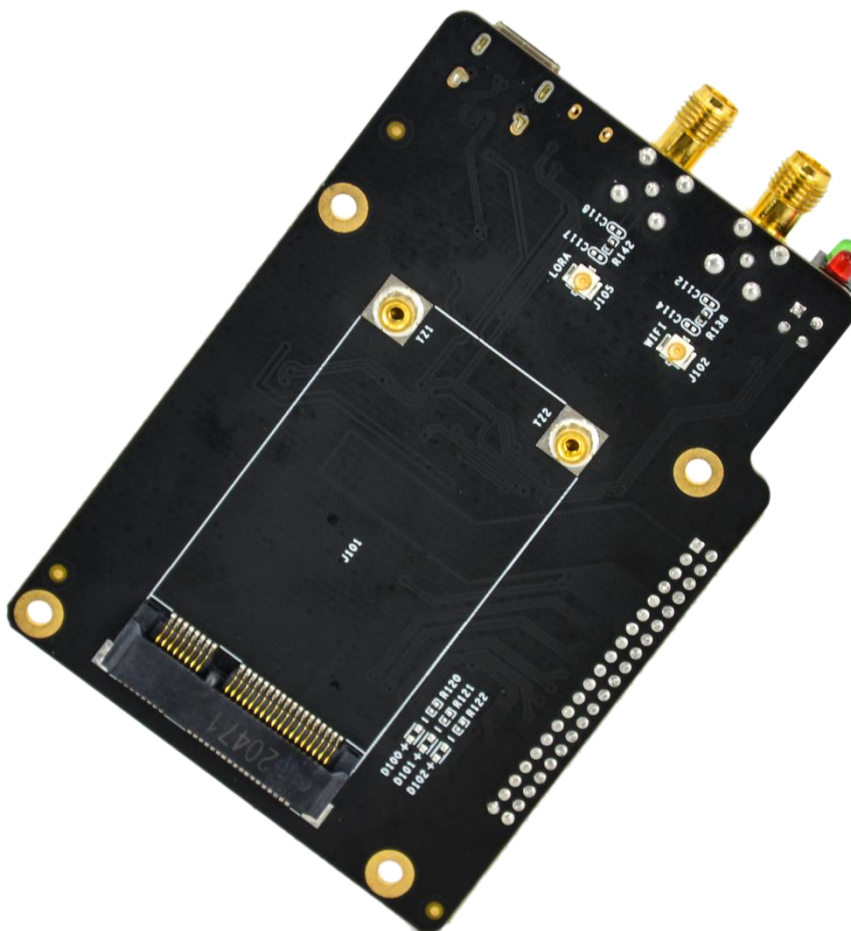

Figure 1 DEBIX LoRa Board

REVISION HISTORY

Rev.	Date	Description
1.0	2022.07.24	First edition

INDEX



Chapter 1 Security	4
1.1. Safety Precaution	4
1.2. Safety Instruction	4
1.3. Declaration of Compliance	5
1.4. Technical Support	6
Chapter 2 DEBIX LoRa board Introduction	7
2.1. Overview	8
2.2. Interface	9
2.2.1. Debug Interface	9
2.2.2. Mini PCIe	9
2.2.3. LED & Key	11
2.3. Packing List	12
Chapter 3 Getting started	13
3.1. Hardware connection	13
Chapter 4 Function Examples	16
4.1. Usage of LoRa module	16

Chapter 1 Security

1.1. Safety Precaution

The following messages inform how to make each cable connection. In most cases, you will simply need to connect a standard cable.

Table 1 Terms and conventions

Symbol	Meaning
<p><i>Warning!</i></p> 	<p>Always disconnect the power cord from the chassis whenever there is no workload required on it. Do not connect the power cable while the power is on. A sudden rush of power can damage sensitive electronic components. Only experienced electricians should open the chassis.</p>
<p><i>Caution!</i></p> 	<p>Always ground yourself to remove any static electric charge before touching <i>DEBIX</i> product. Modern electronic devices are very sensitive to electric charges. Use a grounding wrist strap at all times. Place all electronic components on a static-dissipative surface or in a static-shielded bag.</p>

1.2. Safety Instruction

To avoid malfunction or damage to this product please observe the following:

1. Disconnect the device from the DC power supply before cleaning. Use a damp cloth. Do not use liquid detergents or spray-on detergents.
2. Keep the device away from moisture.
3. During installation, set the device down on a reliable surface. Drops and bumps will lead to damage.
4. Before connecting the power supply, ensure that the voltage is in the required range, and the way of wiring is correct.
5. Carefully put the power cable in place to avoid stepping on it.
6. If the device is not used for a long time, power it off to avoid damage caused by sudden

overvoltage.

7. Do not pour liquid into the venting holes of the enclosure, as this could cause fire or electric shock.

8. For safety reasons, the device can only be disassembled by professional personnel.

9. If one of the following situations occur, get the equipment checked by service personnel:

- The power cord or plug is damaged.
- Liquid has penetrated into the equipment.
- The equipment has been exposed to moisture.
- The equipment does not work well, or you cannot get it to work according to the user's manual.
- The equipment has been dropped and damaged.
- The equipment has obvious signs of breakage.

10. Do not place the device outside the specified ambient temperature range. This will damage the machine. It needs to be kept in an environment at controlled temperature.



11. Due to the sensitive nature of the equipment, it must be stored in a restricted access location, only accessible by qualified engineer.



DISCLAIMER: Polyhex disclaims all responsibility for the accuracy of any statement of this instructional document.

1.3. Declaration of Compliance

This product has passed the following certifications:

Table 2 Compliance Certification

Symbol	Meaning
	This equipment has passed CE certified.
	This equipment is manufactured in compliance with RoHS regulations.

	This equipment has passed UKCA certified.
	This equipment has passed FCC certified.

1.4. Technical Support

1. Visit DEBIX website <https://www.debix.io/> where you can find the latest information about the product.
2. Contact your distributor, sales representative or Polyhex's customer service center for technical support if you need additional assistance. Please have the following info ready before you call:
 - Product name
 - Description of your peripheral attachments
 - Description of your software(operating system, version, application software, etc.)
 - A complete description of the problem
 - The exact wording of any error messages

Discord Community (recommended): <https://discord.com/invite/adaHHaDkH2>

Email: info@debix.io

Chapter 2 DEBIX LoRa board Introduction

DEBIX LoRa board for DEBIX motherboard provides a Mini PCIe interface, and supports access to LoRa module to enable long-range transmissions with low power consumption.

Main features:

- Support Mini PCIe LoRa module.
- Support WiFi, Bluetooth.
- Low power consumption, long distance transmission.

2.1. Overview

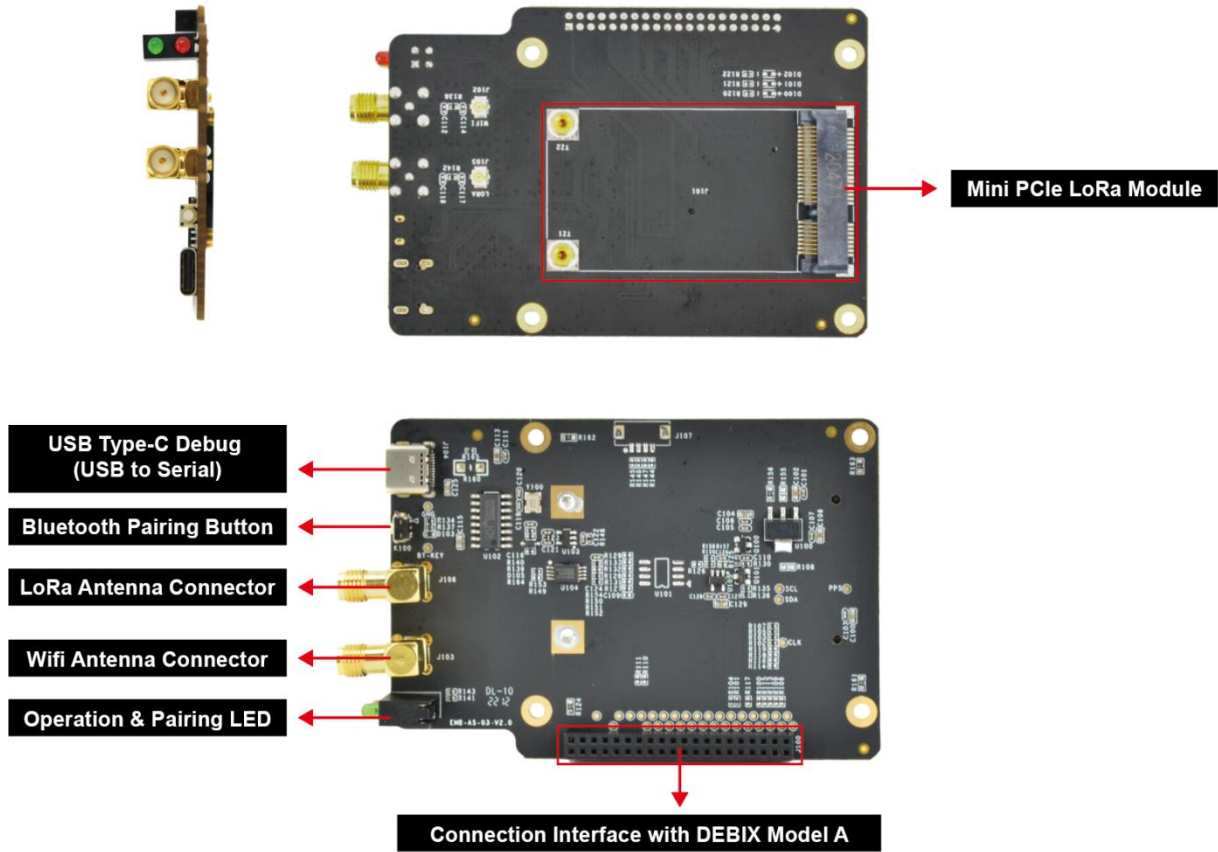

Figure 2 DEBIX LoRa Board

DEBIX LoRa board provides Mini PCIe interface of DEBIX motherboard to support LoRa, WiFi, Bluetooth, etc. The data specifications are as below:

Table 3 DEBIX LoRa Board specification

I/O Interface	
USB	1 x USB Type-C Debug (USB to Serial)
Mini PCIe	1 x Mini PCIe, support LoRa module
LED & Key	<ul style="list-style-type: none"> ● 1 x Operation LED ● 1 x Bluetooth Pairing LED ● 1 x Bluetooth Pairing Key
External	<ul style="list-style-type: none"> ● 1 x WiFi antenna

Antenna	● 1 x LoRa antenna
Storage	2Kbit EEPROM
Clipper Chip	1 x Secure Element, e.g.ATECC608
Power Supply	
Power Input	DC 5V/1A
Mechanical & Environmental	
Size (L x W)	85.0mm x 61.2mm (±0.5mm)
Weight	54g (±0.5g)

2.2. Interface

2.2.1. Debug Interface

DEBIX LoRa board has a USB Type-C Debug interface (J104) as a debug port for DEBIX troubleshooting program.

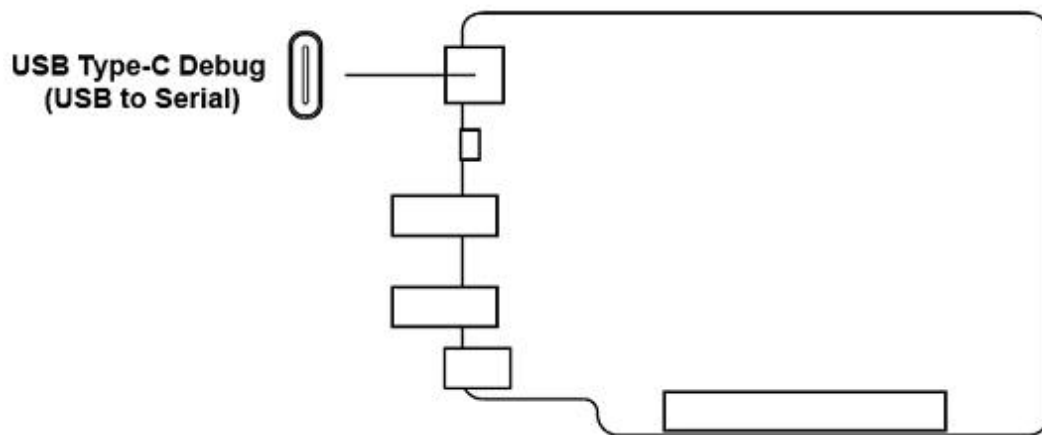

Figure 3 Debug interface

2.2.2. Mini PCIe

DEBIX LoRa board has a PCIe Gen3.0 single lane PCIe controller compatible with the following standards:

- PCI Express Base Specification, Revision 4.0, Version 0.7

- PCI Local Bus Specification, Revision 3.0
- PCI Bus Power Management Specification, Revision 1.2
- PCI Express Card Electromechanical Specification, Revision 1.1

Mini PCIe interface (J101) supports Mini PCIe LoRa module.

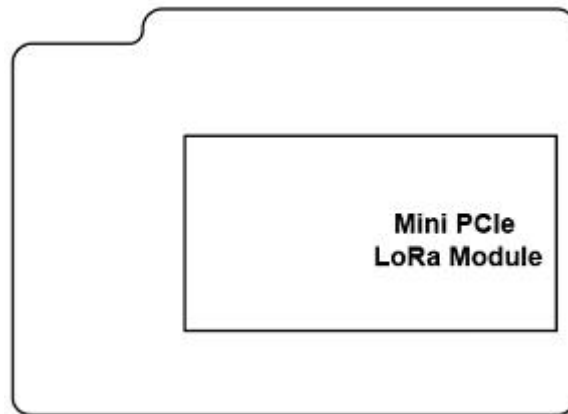

Figure 4 Mini PCIe

The Mini PCIe interface is defined as follows:

Table 4 Pin definition of Mini PCIe

Pin	Definition	Pin	Definition
1	NC	2	LORA_5V
3	NC	4	GND
5	NC	6	NC
7	NC	8	NC
9	GND	10	NC
11	NC	12	NC
13	NC	14	NC
15	GND	16	RF-RWREN
17	ECSP11_SCLK	18	GND
19	ECSP11_MISO	20	NC
21	GND	22	LORA-RST
23	ECSP11_MOSI	24	NC

25	ECSPI1_SSO	26	GND
27	GND	28	NC
29	GND	30	NC
31	NC	32	NC
33	NC	34	GND
35	GND	36	NC
37	GND	38	NC
39	LORA_3V3	40	GND
41	LORA_3V3	42	NC
43	GND	44	NC
45	NC	46	NC
47	NC	48	NC
49	NC	50	GND
51	NC	52	LORA_3V3
53	GND	54	GND
55	GND	56	GND

2.2.3. LED & Key

DEBIX LoRa board has two LED indicators, one Bluetooth pairing button, as shown in the following figure:

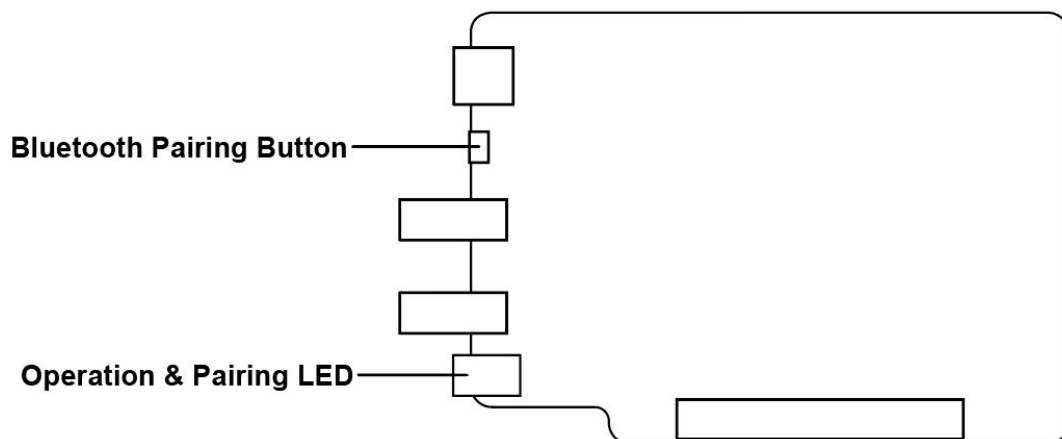

Figure 5 LED & Key

Table 5 Description of LED & Key

LED & Key	Status	Description
Operation LED	Lighting	Power is on
	off	Power is off
Pairing LED	Blinking	Bluetooth pairing is successful
	off	System fault
Bluetooth Pairing Button	Long press 5s, Pairing LED blinking	Bluetooth pairing is successful and works

2.3. Packing List

- DEBIX LoRa Board
- LoRa Module (optional)
- Antenna (optional)

Chapter 3 Getting started

3.1. Hardware connection

- **Component Preparation**

- ✓ DEBIX LoRa board, DEBIX motherboard
- ✓ LoRa Module
- ✓ 2 x External Antenna

The connection steps are as follows:

1. Install the LoRa module onto the DEBIX LoRa board, as shown below:



Figure 6 Connect DEBIX LoRa board with LoRa module

2. Connect two antennas to the antenna interfaces of the DEBIX LoRa board, as shown in the following figure:



Figure 7 Antenna

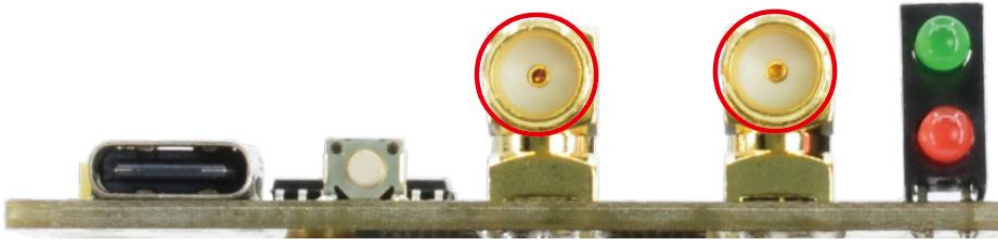

Figure 8 Antenna interface



Figure 9 Connect DEBIX LoRa with antenna

3. Align the female header of DEBIX LoRa board with the top pin header of DEBIX motherboard, and press to insert, as shown in the following figure:

NOTE

It is necessary to confirm that the female header of DEBIX LoRa board are aligned one by one with the top pin header on the DEBIX motherboard to avoid damage to the board caused by power on after misalignment.

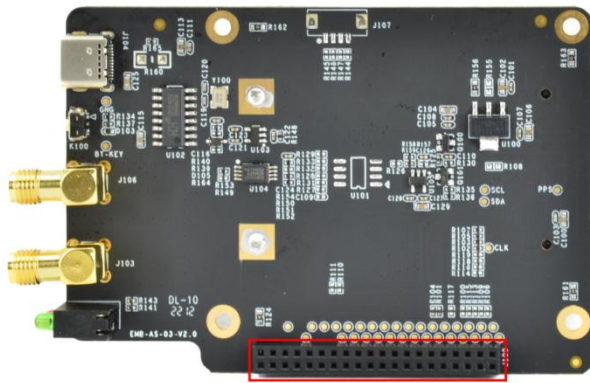

Figure 10 Female header of DEBIX LoRa board

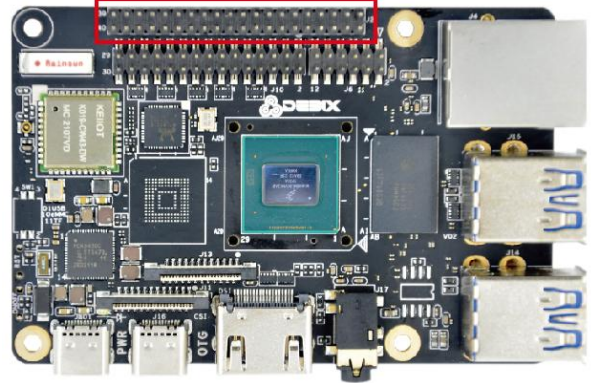

Figure 11 Pin header of DEBIX motherboard

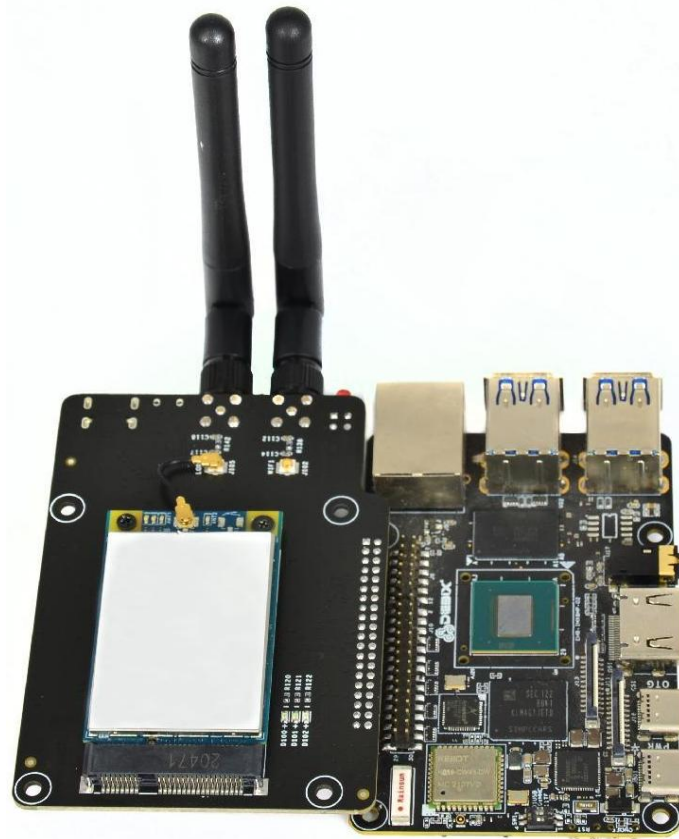

Figure 12 Connect DEBIX with DEBIX LoRa board

4. Insert the Micro SD card with DEBIX system into the slot of DEBIX motherboard, connect DEBIX peripherals (HDMI monitor, keyboard, mouse, network cable), power up DEBIX, and the DEBIX can be used normally.

Chapter 4 Function Examples

4.1. Usage of LoRa module

- **Component Preparation**
 - ✓ DEBIX LoRa board, DEBIX motherboard
 - ✓ WiFi antenna, LoRa antenna, LoRa module
 - ✓ Peripherals (HDMI, keyboard, mouse, network cable)

- **LoRa module hardware resources:**

Table 6 LoRa module hardware resources

Function name	I/O name	Device node	Description
SPI	ECSPI1-SS0	/dev/spidev0.0	SPI chip select
	ECSPI1-MOSI		SPI data output
	ECSPI1-MISO		SPI data input
	ECSPI1-SCLK		SPI clock
LORA_RST	GPIO1-IO11	/dev/lora_reset	Lora module reset
LORA-PWR-EN	CAN1-TXD	/dev/lora_en	Lora module enable power

1. Connect DEBIX LoRa board and DEBIX motherboard as the steps described above, and power up DEBIX;
2. **Ubuntu Desktop Setting:**
 - Enter the DEBIX system desktop, select **Add-on Board APP**, and switch to the corresponding device tree;

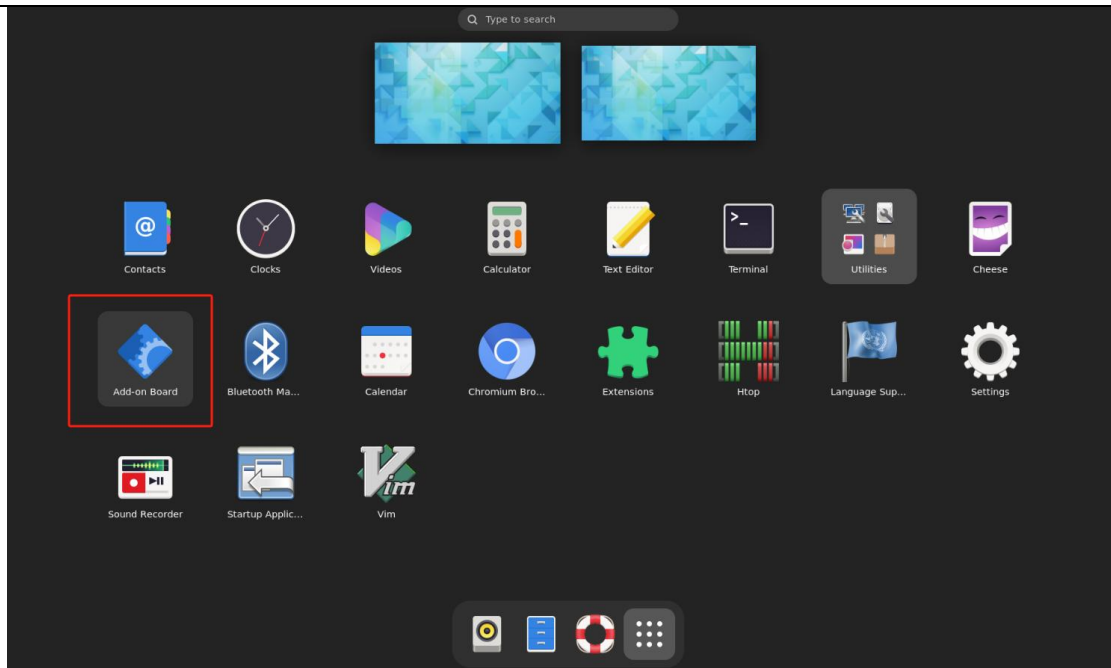

Figure 13

- In the pop-up "DEBIX add on board dtb file selection" window, select **Debix board** and click **OK**.

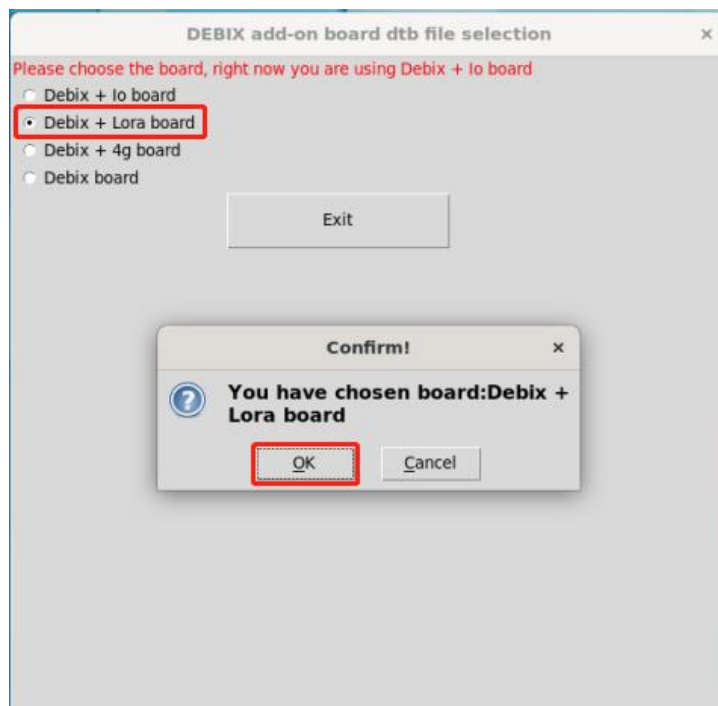

Figure 14

- Select **None** for Panel and click **OK**.

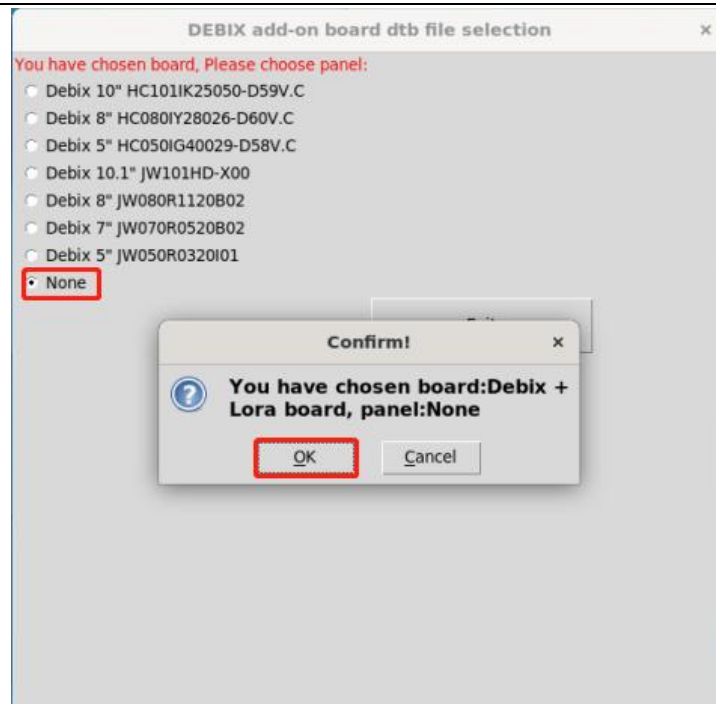

Figure 15

- Click **Start**, and click **OK**.

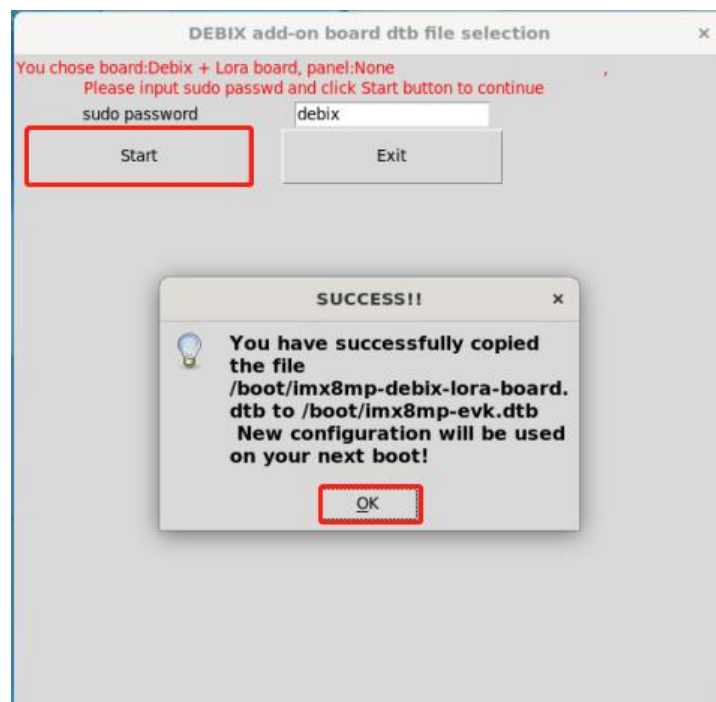

Figure 16

- Reboot the device to take effect the above settings.

3. Check whether LoRa is supported in the system:

- Open the terminal, run the command `ls /dev/lora*`, the output is as follows:

```
/dev/lora_en /dev/lora_reset
```

- The existence of `lora_en` and `lora_reset` files in the `/dev/` directory proves that the DEBIX kernel supports LoRa.

4. Test whether the LoRa module is normal:

- Run the command `cd /opt/packet_forwarder/`, and `sudo ./lora_pkt_fwd`, the output is as follows:

```
*** Packet Forwarder ***
Version: 1.0.5
*** SX1302 HAL library version info ***
Version: 1.0.5;
***
INFO: Little endian host
INFO: found configuration file global_conf.json, parsing it
INFO: global_conf.json does contain a JSON object named SX130x_conf, parsing
SX1302 parameters
INFO: spidev_path /dev/spidev0.0, lorawan_public 1, clksrc 0, full_duplex 0
lgw_board_setconf:236: Note: board configuration: spidev_path: /dev/spidev0.0,
lorawan_public:1, clksrc:0, full_duplex:0
INFO: antenna_gain 0 dBi
...
Note: success connecting the concentrator
Loading AGC fw for sx1250
Loading ARB fw
INFO: [main] concentrator started, packet can now be received
INFO: concentrator EUI: 0x0016c001ff1a8f79
```

- The output shows "success connecting the concentrator", indicating that the LoRa module has been successfully connected.